



PHILIPS

Fortimo

LEDFlex system



Design-in Guide

Fortimo LEDFlex system for ultimate shopping experience

June 2019

Contents

Important	3	Electrical installation	10
Warranty	3	Drivers for LEDFlex	10
Warnings and system restrictions	3	Series and Parallel connections (for class 2 in North America)	10
System disposal	3		
Products and tools	4	Maximum length of a series connection	11
Thermal design	5	Driver mapping	12
Introduction	5	EMC	18
Key Definitions:	5	Chemical compatibility	19
Test Requirements	5	Examples of system calculation	20
Module Tcase point location	5		
Cooling	6		
Drivers	6		
Tape adhesion	7		
Cutting, connecting and tape adhesion	8		
Cutting and connecting the LEDFlex with 5cm (C5) cuttable length	8		
Cutting and connecting the LEDFlex with 10cm (C10) cuttable length	9		

Important

Please take the time to read this installation guide before you install this Philips LED product and driver. The guide contains important information regarding installation and operation.

Warranty

Warranty only applies when the appropriate Philips LED driver and Philips cabling (as described in this guide and leaflets) are used. Please visit our website www.philips.com/oem or contact your local sales office for more information.

⚠ Warnings and system restrictions

- This product is for built-in use only. (Its required to cover the LEDFlex)
- More detailed information on design-in can be found on our website: www.philips.com/oem
- Do not switch on the LEDFlex when on the reel.
- This product may require a heatsink.
- The installation guide does not supersede local or (inter)national regulations for electrical installations.
- This Philips LED product and LED driver must be installed by a professional electrician in accordance with the applicable and appropriate electrical codes and the instructions provided by Philips.
- Do not connect this LED product directly to mains voltages.
- This is a 24 V DC product and should always be connected to a SELV (Safety Extra Low Voltage) driver. Ensure proper routing of the cable to avoid cable damage.
- North America; This Philips LED product is designed to be connected to a circuit from a class 2 power source (Philips Xitanium LED power driver or LED transformer) with energy-limited supply.
- Do not load the power driver beyond 90% of its rated maximum power.
- Before installation, maintenance or cleaning, always first switch off or disconnect the power and follow the appropriate safety procedures.
- Do not apply force on the electrical components when applying the LEDFlex.
- These modules are designed with ESD protection but please take into account the max level indicated in the datasheet.
- Do not make sharp bends with electrical wires.
- Avoid contact between cables and sharp edges.
- Due to the variety of designs and brands in which the Philips LED products can be installed, you may need to use customized mounting accessories to fit the specific design you are using.
- This product is designed for dry locations only.

- The fixing/cooling surface must be cleaned before installing the LEDFlex modules to remove all dirt, dust and grease.
Please refer to the instructions of 3M™ for best tape fixation (tape type: 5915 of 5952 family)
- Do not mount on Plasticized Vinyl, EVA, Polyethylene, Polypropylene, PVF, Silicone, and PTFE. For an indication of materials that are suitable for mounting refer to the extensive information from 3M™ (tape type: 5915 of 5952 family)
- None of the components of the LEDFlex (substrate, LED, electronic components etc.) may be exposed to tensile or compressive stresses.

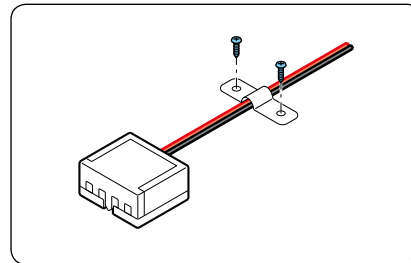

1) Strain relief

- Use a strain relief to prevent shear- and peel forces on the LED module through the connector and/or wiring.
- Disclaimer: Philips has chosen the the best suitable tape in the market at the time of product release. Philips is not liable for loosening of the tape over time and/or its consequences. The Datasheet of the 3M™ VHB™ Tape 5915 can be found here: <https://3m.citration.com/pif/000074?locale=en-US>
- If you require further support, please contact your local Philips sales organization.

System disposal

We recommend that the CertaFlux RDL module and its components are disposed of in an appropriate way at the end of their (economic) lifetime. The modules are in effect normal pieces of electronic equipment containing components that are currently not considered to be harmful to the environment. We therefore recommend that these parts are disposed of as normal electronic waste, in accordance with local regulations.

Products and tools

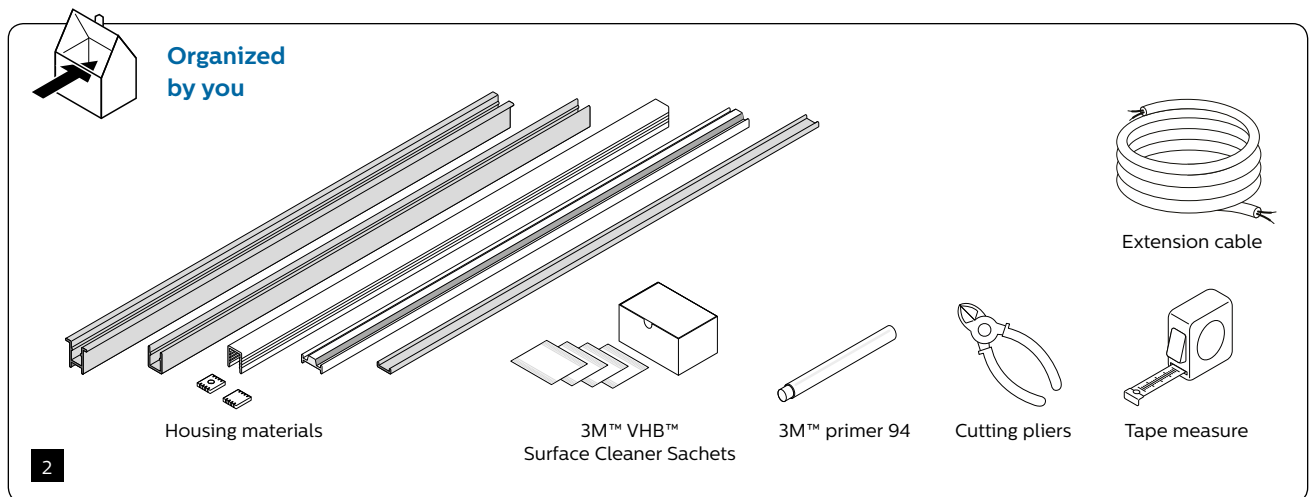
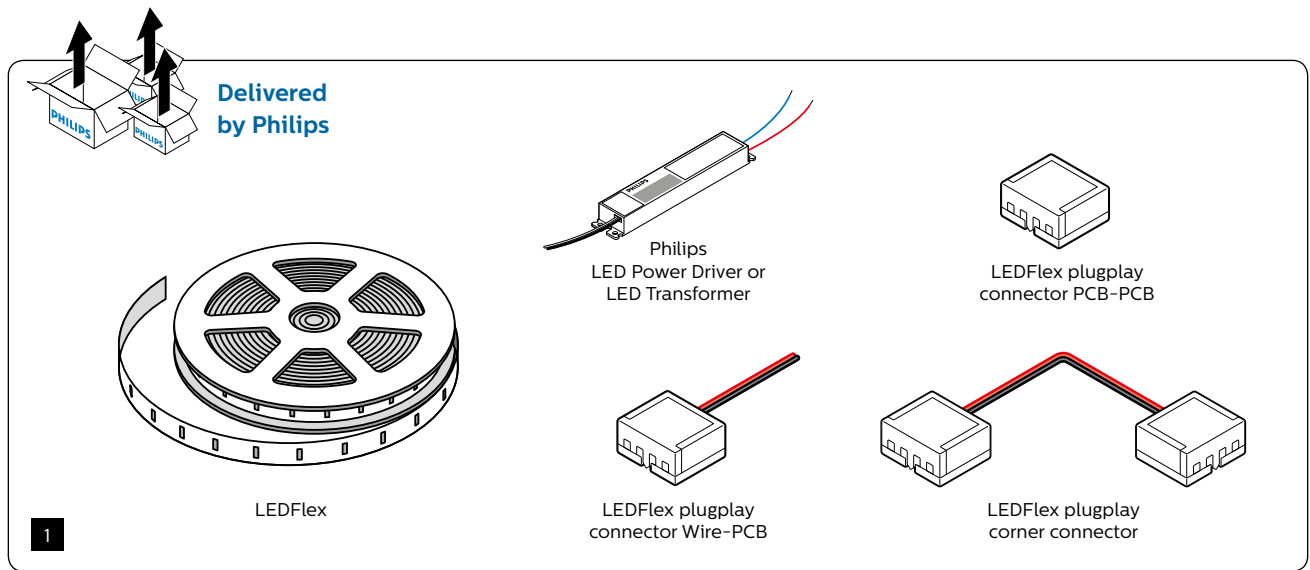

Thermal design

Introduction

Attention needs to be paid to thermal design-in for LED-modules and drivers to ensure optimum performance and life time of the luminaire. The critical thermal management items for the LED module are set out in this chapter in order to facilitate the design-in. If these thermal items are taken into account, this will help to ensure optimum performance and lifetime of the LED system.

Relevant definitions are explained along with guidance on how and where to measure the temperatures.

Key Definitions:

Module temperature: This is the temperature measured at the specified Tcase or Tc point of the module. This temperature is directly related to the LED junction temperature, which is the critical parameter for operation.

Ambient temperature: This is the temperature of the air surrounding the luminaire in the test environment or application. The module and driver temperature increases, by approximation, linearly with the ambient temperature. This relation can be used to predict module and driver temperatures at a different ambient temperature.

Tc nominal: This is the module temperature at which the performance is specified.

Tc life: This is the module or driver temperature (equal or higher than Tc nominal) at which the lifetime of the module (e.g. lumen maintenance of LxxByy) is specified.

Tc max: This is the maximum module or driver temperature (equal or higher than Tc life) to stay within safety limits. This temperature must not be exceeded, even in case of fan failure. The specified Tc nominal, Tc life, and Tc max are listed in the relevant datasheets that can be found on our website philips.com/oem

Test Requirements

Measurements shall not be taken until the luminaire has stabilized thermally, i.e. temperatures are changing at a rate less than 1 °C per hour (see also the relevant clauses in IEC 60598-1). For ANSI/UL 8750 the test is to continue until constant temperatures are obtained. A temperature is considered constant if:

- The test has been running for at least 3 hours, and
- Three successive readings, taken at 15-minute intervals, are within 1°C (1.8°F) of one another and are still not rising.

Module Tcase point location

The Tcase point of the LEDFlex module is located on the top side of the module. Please refer to the datasheet for the exact location Driver Tcase point location. The Tcase point on the driver is indicated by a point or an asterisk with the Tc caption. Please refer to the driver datasheet for the exact location. The thermocouple can be attached with a high temperature glue or Kapton tape.

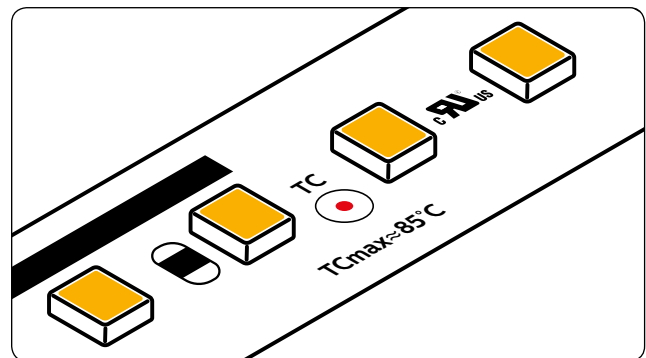

2) Indication of Tc measurement point

Thermal design

Cooling

The LEDFlex modules have a relatively small footprint in relation to their electrical and thermal power. A good thermal contact via the 3M™ tape to an adequate heat sink, is a necessity for a good luminaire. To make good contact a certain pressure should be applied during installation. When applying pressure to the LEDFlex take care not to damage the electronics by exerting force on them and avoid ESD of more than 8kV. The heat sink surface must be smooth and free of burrs to obtain optimal contact. The heat sink should not be locked up in a confined space. It should be in contact with the ambient air for optimal heat transfer to the ambient.

Drivers

If placed in the luminaire drivers are preferably placed as far away as possible from the modules to prevent heating interaction. If placed in a separate driver compartment they are preferably mounted on the inner surface of the compartment. Do not place the driver on a heat sink that is used for cooling the modules. If so, it will be heated by the thermal losses of the LED –modules.

To warrant the lifetime of the driver, two parameters are key:

1. Ambient operating temperature. The ambient operating temperature is given in the product datasheet.
2. Tc life: The temperature measured at the Tcase point of the LEDFlex module is located on the top side. Please refer to the datasheet for the exact Driver Tcase point location and Tc life value.

In many cases the LEDFlex is self cooling, meaning it does not require a heatsink. Below you find an indicative table of self cooling LEDFlex products when mounted as can be seen in picture 3.

The self cooling values are an indication only and should always be verified by a Tc measurement. The self cooling indication is given for a setup indicated in the below picture (picture 3). Where the optical efficiency of the cover is 85%.

Note:

The self cooling values are an indication only and should always be verified by Tc measurement. The self cooling indication is given for a setup indicated in the below picture. Where the optical efficiency of the cover is 85%

Self cooling table

Commercial product name (8xx)	Ta 25	Ta 30	Ta 35	Ta 40	Ta 45	Ta 50
Fortimo LEDFlex 5m 1000lm/m 8xx C10 G1	self cooling	self cooling	self cooling	self cooling	self cooling	self cooling
Fortimo LEDFlex 5m 1500lm/m 8xx C10 G1	self cooling	self cooling	self cooling	self cooling	self cooling	
Fortimo LEDFlex 5m 2000lm/m 8xx C10 G1	self cooling	self cooling	self cooling			
Fortimo LEDFlex 5m 2500lm/m 8xx C10 G1	self cooling					

Commercial product name (9xx)	Ta 25	Ta 30	Ta 35	Ta 40	Ta 45	Ta 50
Fortimo LEDFlex 5m 1000lm/m 9xx C5 G1	self cooling	self cooling	self cooling	self cooling	self cooling	self cooling
Fortimo LEDFlex 5m 1500lm/m 9xx C5 G1	self cooling	self cooling	self cooling	self cooling		
Fortimo LEDFlex 5m 2000lm/m 9xx C5 G1	self cooling	self cooling				
Fortimo LEDFlex 5m 2500lm/m 9xx C5 G1						

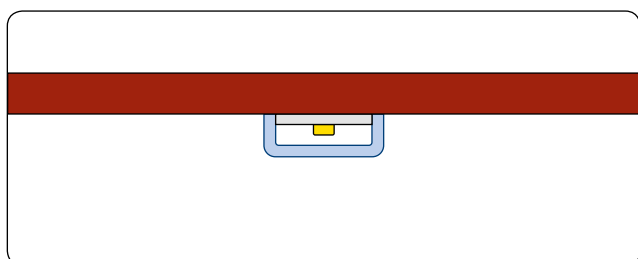

3) Orientation and luminaire type of LEDFlex for selfcooling definition.

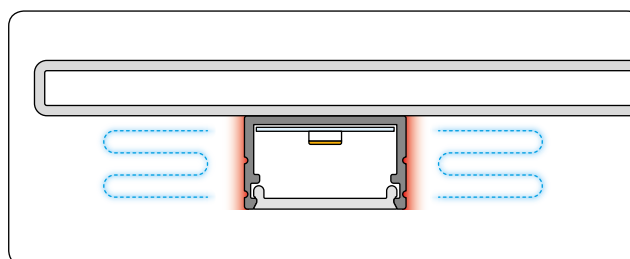

4) Example non-selfcooling heat dissipation.

Cutting, connecting and tape adhesion

Tape adhesion

LedFlex is available in two cutting lengths; 5cm (C5) and 10cm (C10). Below you find how these products should be cut to size, connected to the connector and mount on the base material with the adhesive tape.

- 1 Clean the surface with 3M™ VHB™ Surface Cleaner Sachets
- 2 Use primer for adhesion on plastics only. Apply a very thin layer, allow at least 10mins to dry before applying the tape
- 3 For details on primers always check the 3M™ user manual for VHB tapes
- 4 Apply medium pressure to the LEDFlex for proper thermal/mechanical contact

Cutting, connecting and tape adhesion

Cutting and connecting the LEDFlex with 5cm (C5) cuttable length

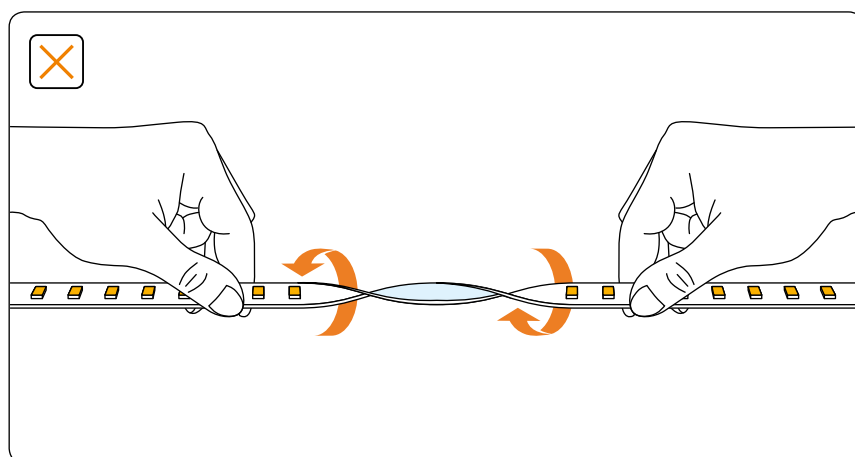
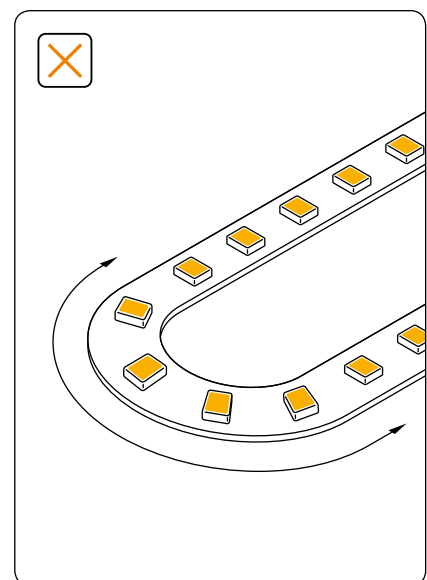
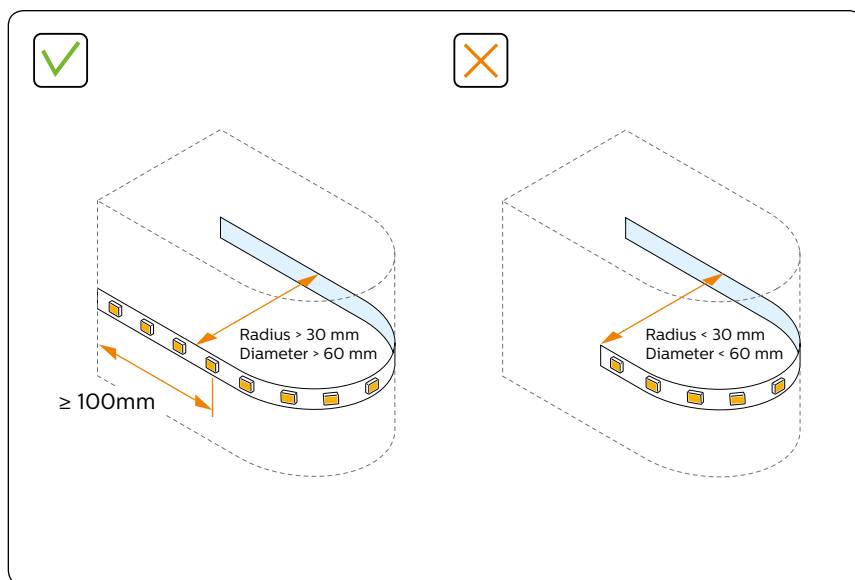
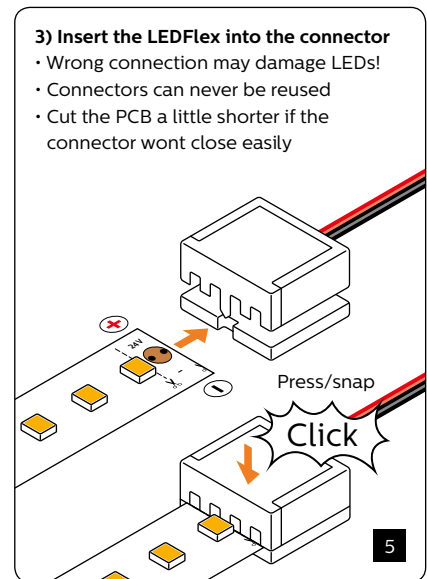
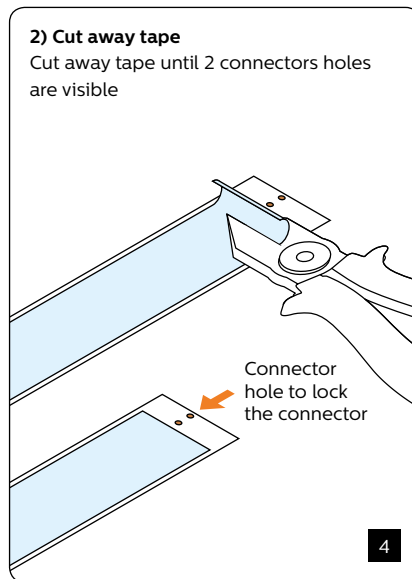
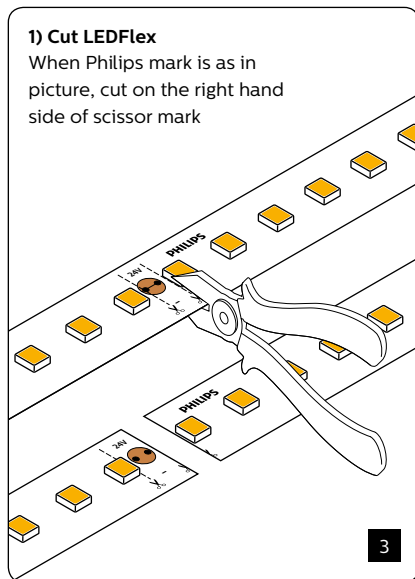

Cutting, connecting and tape adhesion

Cutting and connecting the LEDFlex with 10cm (C10) cuttable length

Connect to driver

CRI80 version - cuttable up to 10 cm

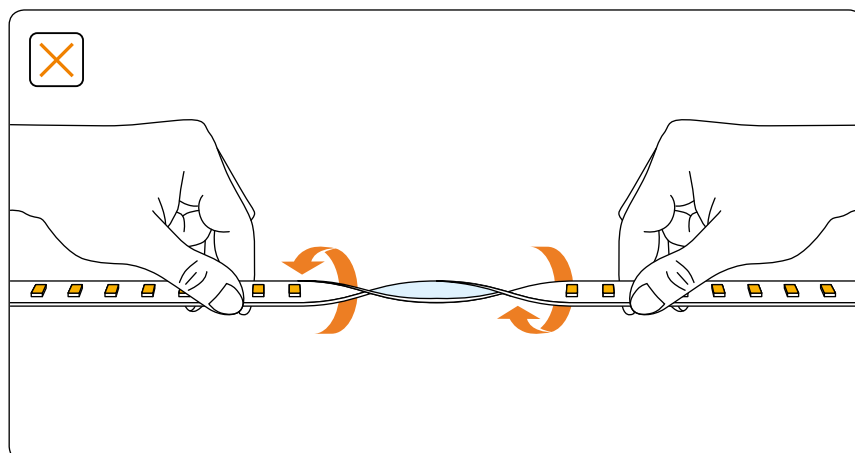
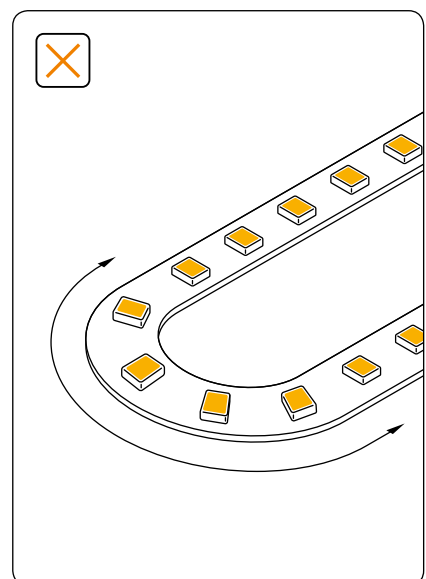
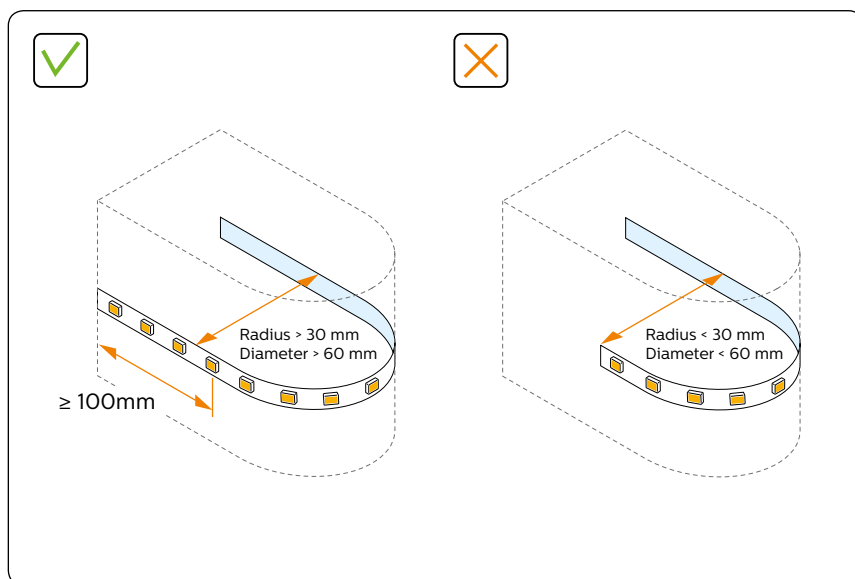
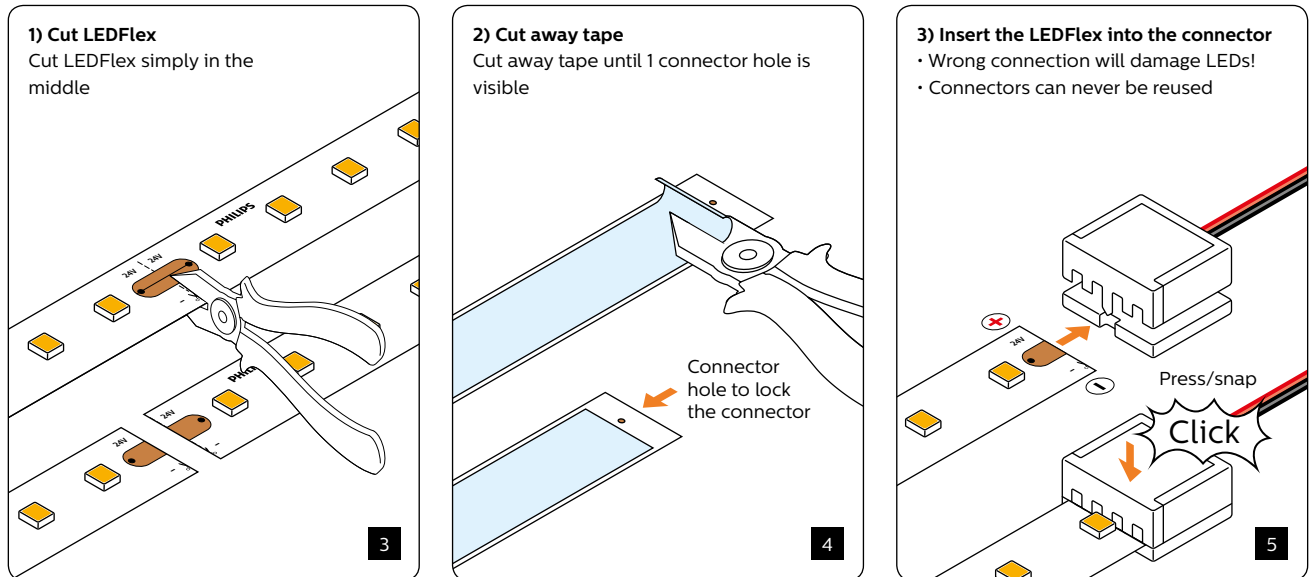

Electrical installation

Drivers for LEDFlex

To power the LEDFlex, two types of power sources can be used:

- Philips LED transformers (independent)
- Philips LED Power drivers (Built-in, need to be placed in a housing)
- A list of drivers and transformers can be found in table 3

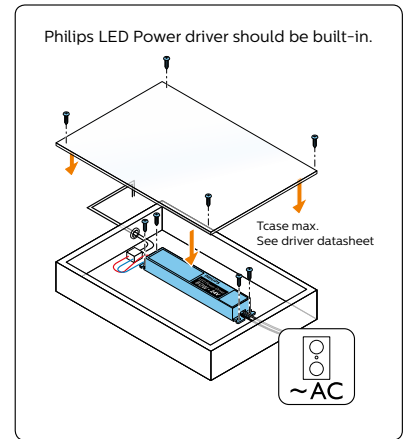

Series and Parallel connections (for class 2 in North America)

You can make any combination of LEDFlex but take into account all of the below restrictions:

- For the maximum length of a series connection, follow table 1 or 2; maximum length of a series connection
- Never exceed 4.2 A and/or 100W for a series connection. (one string)
- Do not exceed 90% of the maximum load indicated on the driver

Example parallel connections (more strings)

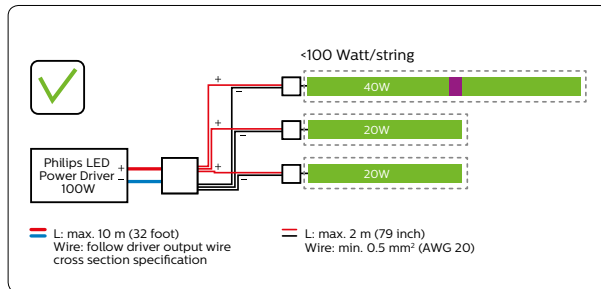

Example series connections (one string)

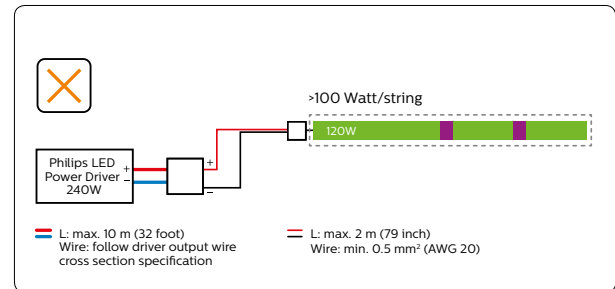

Series and Parallel connections (outside North America)

You can make any combination of LEDFlex but take into account all of the below restrictions:

- For the maximum length of a series connection, follow table 1 or 2; maximum length of a series connection
- Never exceed 5 A and/or 120Watt for a series connection. (one string)
- Do not exceed 90% of the maximum load indicated on the driver
- Choose extensions cables that match the current to prevent overheating

Example parallel connections (more strings)

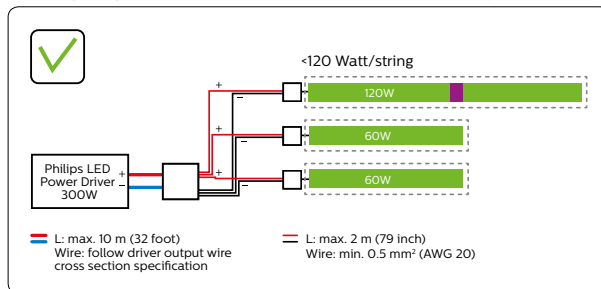

Example series connections (one string)

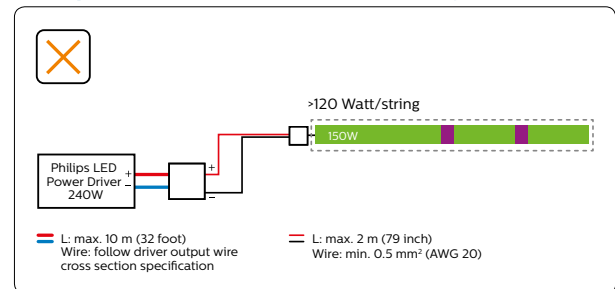

Maximum length of a series connection

In the datasheet you find the maximum length of the LEDFlex with the minimum connector wire 250mm at the Tc nominal. The maximum string length depends on: 1)the type of LEDFlex, 2)the connector wire used, 3)the extension wire used, and 4) the Temperature (Tc). Please find in the tables below the maximum length of the LEDFlex in different configurations, and at two Tc point for your indication of temperature dependency. As a last requirement; Reduce the length of the LEDFlex to not exceed the maximum load of the chosen driver.

Table 1. maximum length of LEDFlex at Tc= 65

Commercial product name	Fortimo LEDFlex connector wire 250mm	Fortimo LEDFlex connector wire 500mm	Fortimo LEDFlex connector wire 2000mm	Fortimo LEDFlex connector wire 250mm + 5m extension cable	Fortimo LEDFlex connector wire 250mm + 10m extension cable
	Max Length (m)	Max Length (m)	Max Length (m)	Max Length (m)	Max Length (m)
Fortimo LEDFlex 5m 1000lm/m 8xx C10 G1	12.0	12.0	11.5	11.0	9.5
Fortimo LEDFlex 5m 1500lm/m 8xx C10 G1	9.0	9.0	8.0	7.5	6.5
Fortimo LEDFlex 5m 2000lm/m 8xx C10 G1	7.0	7.0	6.0	5.5	4.5
Fortimo LEDFlex 5m 2500lm/m 8xx C10 G1	5.0	5.0	4.5	4.0	3.0
Fortimo LEDFlex 5m 1000lm/m 9xx C5 G1	12.0	12.0	11.0	10.5	9.0
Fortimo LEDFlex 5m 1500lm/m 9xx C5 G1	9.0	9.0	8.0	7.5	6.5
Fortimo LEDFlex 5m 2000lm/m 9xx C5 G1	7.0*	7.0*	6.5	6.0	5.0
Fortimo LEDFlex 5m 2500lm/m 9xx C5 G1	5.0	5.0	5.0	5.0	4.0

* For Fortimo LEDFlex 5m 2000lm/m 927 C5 G1 this is reduced to 6.5 meter.

Remark: If you have a question on a specific combination, please contact your local sales representative.

Table 2. maximum length of LEDFlex at Tc=45

Commercial product name	Fortimo LEDFlex connector wire 250mm	Fortimo LEDFlex connector wire 500mm	Fortimo LEDFlex connector wire 2000mm	Fortimo LEDFlex connector wire 250mm + 5m extension cable	Fortimo LEDFlex connector wire 250mm + 10m extension cable
	Max Length (m)	Max Length (m)	Max Length (m)	Max Length (m)	Max Length (m)
Fortimo LEDFlex 5m 1000lm/m 8xx C10 G1	12.0	12.0	11.0	10.5	9.0
Fortimo LEDFlex 5m 1500lm/m 8xx C10 G1	8.5	8.5	7.5	7.0	6.0
Fortimo LEDFlex 5m 2000lm/m 8xx C10 G1	6.5	6.5	5.5	5.0	4.0
Fortimo LEDFlex 5m 2500lm/m 8xx C10 G1	5.0	5.0	4.0	3.5	2.5
Fortimo LEDFlex 5m 1000lm/m 9xx C5 G1	11.5	11.5	10.5	10.0	9.0
Fortimo LEDFlex 5m 1500lm/m 9xx C5 G1	8.5	8.5	8.0	7.0	6.0
Fortimo LEDFlex 5m 2000lm/m 9xx C5 G1	7.0*	7.0*	6.0	5.5	4.5
Fortimo LEDFlex 5m 2500lm/m 9xx C5 G1	5.0	5.0	5.0	4.5	3.5

* For Fortimo LEDFlex 5m 2000lm/m 927 C5 G1 this is reduced to 6.5 meter.

Remark: If you have a question on a specific combination, please contact your local sales representative.

Driver mapping

Tabel 3. Maximum meters LEDFlex per driver type with 90% driver load. If this value is bigger than the maximum allowed string length (see table 1 or 2); create a parallel connection.

		Description	LED Transformer 60W 24VDC			LED Transformer 120W 24VDC		
			9137 100 32267			9137 100 32567		
		Type	independent			independent		
		Class 2 UL Certified	no			no		
		extension wire length (m)	0	5 (-5%)	10 (-10%)	0	5 (-5%)	10 (-10%)
12 NC	Discription	Power (W/m)						
929001490880	Fortimo LEDFlex 1000lm/m 830 C10 G1	7,1	7,6	7,2	6,8	15,2	14,5	13,7
929001490980	Fortimo LEDFlex 1000lm/m 840 C10 G1	6,6	8,2	7,8	7,4	16,4	15,5	14,7
929001491080	Fortimo LEDFlex 1000lm/m 827 C10 G1	7,4	7,3	6,9	6,6	14,6	13,9	13,1
929001491180	Fortimo LEDFlex 1000lm/m 865 C10 G1	6,6	8,2	7,8	7,4	16,4	15,5	14,7
929001491280	Fortimo LEDFlex 1500lm/m 830 C10 G1	10,9	5,0	4,7	4,5	9,9	9,4	8,9
929001491380	Fortimo LEDFlex 1500lm/m 840 C10 G1	10,0	5,4	5,1	4,9	10,8	10,3	9,7
929001491480	Fortimo LEDFlex 1500lm/m 827 C10 G1	11,2	4,8	4,6	4,3	9,6	9,2	8,7
929001491580	Fortimo LEDFlex 1500lm/m 865 C10 G1	10,0	5,4	5,1	4,9	10,8	10,3	9,7
929001491680	Fortimo LEDFlex 2000lm/m 830 C10 G1	14,9	3,6	3,4	3,3	7,2	6,9	6,5
929001491780	Fortimo LEDFlex 2000lm/m 840 C10 G1	13,8	3,9	3,7	3,5	7,8	7,4	7,0
929001491880	Fortimo LEDFlex 2000lm/m 827 C10 G1	15,6	3,5	3,3	3,1	6,9	6,6	6,2
929001491980	Fortimo LEDFlex 2000lm/m 865 C10 G1	13,8	3,9	3,7	3,5	7,8	7,4	7,0
929001492080	Fortimo LEDFlex 2500lm/m 830 C10 G1	18,9	2,9	2,7	2,6	5,7	5,4	5,1
929001492180	Fortimo LEDFlex 2500lm/m 840 C10 G1	17,6	3,1	2,9	2,8	6,1	5,8	5,5
929001492280	Fortimo LEDFlex 2500lm/m 827 C10 G1	19,9	2,7	2,6	2,4	5,4	5,2	4,9
929001492380	Fortimo LEDFlex 2500lm/m 865 C10 G1	17,6	3,1	2,9	2,8	6,1	5,8	5,5
929001489280	Fortimo LEDFlex 1000lm/m 930PW C5 G1	8,2	6,6	6,3	5,9	13,2	12,5	11,9
929001489380	Fortimo LEDFlex 1000lm/m 940PW C5 G1	7,6	7,1	6,8	6,4	14,2	13,5	12,8
929001489480	Fortimo LEDFlex 1000lm/m 927 C5 G1	8,6	6,3	6,0	5,7	12,6	11,9	11,3
929001489580	Fortimo LEDFlex 1000lm/m 965 C5 G1	7,6	7,1	6,8	6,4	14,2	13,5	12,8
929001489680	Fortimo LEDFlex 1500lm/m 930PW C5 G1	12,6	4,3	4,1	3,9	8,6	8,1	7,7
929001489780	Fortimo LEDFlex 1500lm/m 940PW C5 G1	11,8	4,6	4,3	4,1	9,2	8,7	8,2
929001489880	Fortimo LEDFlex 1500lm/m 927 C5 G1	13,2	4,1	3,9	3,7	8,2	7,8	7,4
929001489980	Fortimo LEDFlex 1500lm/m 965 C5 G1	11,8	4,6	4,3	4,1	9,2	8,7	8,2
929001490080	Fortimo LEDFlex 2000lm/m 930PW C5 G1	17,1	3,2	3,0	2,8	6,3	6,0	5,7
929001490180	Fortimo LEDFlex 2000lm/m 940PW C5 G1	16,0	3,4	3,2	3,0	6,8	6,4	6,1
929001490280	Fortimo LEDFlex 2000lm/m 927 C5 G1	18,0	3,0	2,9	2,7	6,0	5,7	5,4
929001490380	Fortimo LEDFlex 2000lm/m 965 C5 G1	16,0	3,4	3,2	3,0	6,8	6,4	6,1
929001490480	Fortimo LEDFlex 2500lm/m 930PW C5 G1	21,2	2,5	2,4	2,3	5,1	4,8	4,6
929001490580	Fortimo LEDFlex 2500lm/m 940PW C5 G1	20,0	2,7	2,6	2,4	5,4	5,1	4,9
929001490680	Fortimo LEDFlex 2500lm/m 927 C5 G1	22,5	2,4	2,3	2,2	4,8	4,6	4,3
929001490780	Fortimo LEDFlex 2500lm/m 965 C5 G1	20,0	2,7	2,6	2,4	5,4	5,1	4,9

If you have a question on a specific combination, please contact your local sales representative.

Driver mapping

Tabel 3. Maximum meters LEDFlex per driver type with 90% driver load. If this value is bigger than the maximum allowed string length (see table 1 or 2); create a parallel connection.

		Description	LED Transformer 150W IP67 24VDC 220-240V			LED Transformer 300W IP67 24VDC 220-240V		
			9290 014 85580			9290 014 85680		
		Type	independent			independent		
		Class 2 UL Certified	no			no		
		extension wire length (m)	0	5 (-5%)	10 (-10%)	0	5 (-5%)	10 (-10%)
12 NC	Discription	Power (W/m)						
929001490880	Fortimo LEDFlex 1000lm/m 830 C10 G1	7,1	19,0	18,1	17,1	38,0	36,1	34,2
929001490980	Fortimo LEDFlex 1000lm/m 840 C10 G1	6,6	20,5	19,4	18,4	40,9	38,9	36,8
929001491080	Fortimo LEDFlex 1000lm/m 827 C10 G1	7,4	18,2	17,3	16,4	36,5	34,7	32,8
929001491180	Fortimo LEDFlex 1000lm/m 865 C10 G1	6,6	20,5	19,4	18,4	40,9	38,9	36,8
929001491280	Fortimo LEDFlex 1500lm/m 830 C10 G1	10,9	12,4	11,8	11,1	24,8	23,5	22,3
929001491380	Fortimo LEDFlex 1500lm/m 840 C10 G1	10,0	13,5	12,8	12,2	27,0	25,7	24,3
929001491480	Fortimo LEDFlex 1500lm/m 827 C10 G1	11,2	12,1	11,5	10,8	24,1	22,9	21,7
929001491580	Fortimo LEDFlex 1500lm/m 865 C10 G1	10,0	13,5	12,8	12,2	27,0	25,7	24,3
929001491680	Fortimo LEDFlex 2000lm/m 830 C10 G1	14,9	9,1	8,6	8,2	18,1	17,2	16,3
929001491780	Fortimo LEDFlex 2000lm/m 840 C10 G1	13,8	9,8	9,3	8,8	19,6	18,6	17,6
929001491880	Fortimo LEDFlex 2000lm/m 827 C10 G1	15,6	8,7	8,2	7,8	17,3	16,4	15,6
929001491980	Fortimo LEDFlex 2000lm/m 865 C10 G1	13,8	9,8	9,3	8,8	19,6	18,6	17,6
929001492080	Fortimo LEDFlex 2500lm/m 830 C10 G1	18,9	7,1	6,8	6,4	14,3	13,6	12,9
929001492180	Fortimo LEDFlex 2500lm/m 840 C10 G1	17,6	7,7	7,3	6,9	15,3	14,6	13,8
929001492280	Fortimo LEDFlex 2500lm/m 827 C10 G1	19,9	6,8	6,4	6,1	13,6	12,9	12,2
929001492380	Fortimo LEDFlex 2500lm/m 865 C10 G1	17,6	7,7	7,3	6,9	15,3	14,6	13,8
929001489280	Fortimo LEDFlex 1000lm/m 930PW C5 G1	8,2	16,5	15,6	14,8	32,9	31,3	29,6
929001489380	Fortimo LEDFlex 1000lm/m 940PW C5 G1	7,6	17,8	16,9	16,0	35,5	33,8	32,0
929001489480	Fortimo LEDFlex 1000lm/m 927 C5 G1	8,6	15,7	14,9	14,1	31,4	29,8	28,3
929001489580	Fortimo LEDFlex 1000lm/m 965 C5 G1	7,6	17,8	16,9	16,0	35,5	33,8	32,0
929001489680	Fortimo LEDFlex 1500lm/m 930PW C5 G1	12,6	10,7	10,2	9,6	21,4	20,4	19,3
929001489780	Fortimo LEDFlex 1500lm/m 940PW C5 G1	11,8	11,4	10,9	10,3	22,9	21,7	20,6
929001489880	Fortimo LEDFlex 1500lm/m 927 C5 G1	13,2	10,2	9,7	9,2	20,5	19,4	18,4
929001489980	Fortimo LEDFlex 1500lm/m 965 C5 G1	11,8	11,4	10,9	10,3	22,9	21,7	20,6
929001490080	Fortimo LEDFlex 2000lm/m 930PW C5 G1	17,1	7,9	7,5	7,1	15,8	15,0	14,2
929001490180	Fortimo LEDFlex 2000lm/m 940PW C5 G1	16,0	8,4	8,0	7,6	16,9	16,0	15,2
929001490280	Fortimo LEDFlex 2000lm/m 927 C5 G1	18,0	7,5	7,1	6,8	15,0	14,3	13,5
929001490380	Fortimo LEDFlex 2000lm/m 965 C5 G1	16,0	8,4	8,0	7,6	16,9	16,0	15,2
929001490480	Fortimo LEDFlex 2500lm/m 930PW C5 G1	21,2	6,4	6,0	5,7	12,7	12,1	11,5
929001490580	Fortimo LEDFlex 2500lm/m 940PW C5 G1	20,0	6,8	6,4	6,1	13,5	12,8	12,2
929001490680	Fortimo LEDFlex 2500lm/m 927 C5 G1	22,5	6,0	5,7	5,4	12,0	11,4	10,8
929001490780	Fortimo LEDFlex 2500lm/m 965 C5 G1	20,0	6,8	6,4	6,1	13,5	12,8	12,2

If you have a question on a specific combination, please contact your local sales representative.

Driver mapping

Tabel 3. Maximum meters LEDFlex per driver type with 90% driver load. If this value is bigger than the maximum allowed string length (see table 1 or 2); create a parallel connection.

		Description	Xitanium 77W 100-277V 3.2A			Xitanium 100W 100-277V 4.1A		
		12NC	9290 017 08113			9290 007 71913		
		Type	independent			independent		
		Class 2 UL Certified	class 2			class 2		
		extension wire length (m)	0	5 (-5%)	10 (-10%)	0	5 (-5%)	10 (-10%)
12 NC	Discription	Power (W/m)						
929001490880	Fortimo LEDFlex 1000lm/m 830 C10 G1	7,1	9,8	9,3	8,8	12,7	12,0	11,4
929001490980	Fortimo LEDFlex 1000lm/m 840 C10 G1	6,6	10,5	10,0	9,5	13,6	13,0	12,3
929001491080	Fortimo LEDFlex 1000lm/m 827 C10 G1	7,4	9,4	8,9	8,4	12,2	11,6	10,9
929001491180	Fortimo LEDFlex 1000lm/m 865 C10 G1	6,6	10,5	10,0	9,5	13,6	13,0	12,3
929001491280	Fortimo LEDFlex 1500lm/m 830 C10 G1	10,9	6,4	6,0	5,7	8,3	7,8	7,4
929001491380	Fortimo LEDFlex 1500lm/m 840 C10 G1	10,0	6,9	6,6	6,2	9,0	8,6	8,1
929001491480	Fortimo LEDFlex 1500lm/m 827 C10 G1	11,2	6,2	5,9	5,6	8,0	7,6	7,2
929001491580	Fortimo LEDFlex 1500lm/m 865 C10 G1	10,0	6,9	6,6	6,2	9,0	8,6	8,1
929001491680	Fortimo LEDFlex 2000lm/m 830 C10 G1	14,9	4,7	4,4	4,2	6,0	5,7	5,4
929001491780	Fortimo LEDFlex 2000lm/m 840 C10 G1	13,8	5,0	4,8	4,5	6,5	6,2	5,9
929001491880	Fortimo LEDFlex 2000lm/m 827 C10 G1	15,6	4,4	4,2	4,0	5,8	5,5	5,2
929001491980	Fortimo LEDFlex 2000lm/m 865 C10 G1	13,8	5,0	4,8	4,5	6,5	6,2	5,9
929001492080	Fortimo LEDFlex 2500lm/m 830 C10 G1	18,9	3,7	3,5	3,3	4,8	4,5	4,3
929001492180	Fortimo LEDFlex 2500lm/m 840 C10 G1	17,6	3,9	3,7	3,5	5,1	4,9	4,6
929001492280	Fortimo LEDFlex 2500lm/m 827 C10 G1	19,9	3,5	3,3	3,1	4,5	4,3	4,1
929001492380	Fortimo LEDFlex 2500lm/m 865 C10 G1	17,6	3,9	3,7	3,5	5,1	4,9	4,6
929001489280	Fortimo LEDFlex 1000lm/m 930PW C5 G1	8,2	8,5	8,0	7,6	11,0	10,4	9,9
929001489380	Fortimo LEDFlex 1000lm/m 940PW C5 G1	7,6	9,1	8,7	8,2	11,8	11,3	10,7
929001489480	Fortimo LEDFlex 1000lm/m 927 C5 G1	8,6	8,1	7,7	7,3	10,5	9,9	9,4
929001489580	Fortimo LEDFlex 1000lm/m 965 C5 G1	7,6	9,1	8,7	8,2	11,8	11,3	10,7
929001489680	Fortimo LEDFlex 1500lm/m 930PW C5 G1	12,6	5,5	5,2	5,0	7,1	6,8	6,4
929001489780	Fortimo LEDFlex 1500lm/m 940PW C5 G1	11,8	5,9	5,6	5,3	7,6	7,2	6,9
929001489880	Fortimo LEDFlex 1500lm/m 927 C5 G1	13,2	5,3	5,0	4,7	6,8	6,5	6,1
929001489980	Fortimo LEDFlex 1500lm/m 965 C5 G1	11,8	5,9	5,6	5,3	7,6	7,2	6,9
929001490080	Fortimo LEDFlex 2000lm/m 930PW C5 G1	17,1	4,1	3,9	3,6	5,3	5,0	4,7
929001490180	Fortimo LEDFlex 2000lm/m 940PW C5 G1	16,0	4,3	4,1	3,9	5,6	5,3	5,1
929001490280	Fortimo LEDFlex 2000lm/m 927 C5 G1	18,0	3,9	3,7	3,5	5,0	4,8	4,5
929001490380	Fortimo LEDFlex 2000lm/m 965 C5 G1	16,0	4,3	4,1	3,9	5,6	5,3	5,1
929001490480	Fortimo LEDFlex 2500lm/m 930PW C5 G1	21,2	3,3	3,1	2,9	4,2	4,0	3,8
929001490580	Fortimo LEDFlex 2500lm/m 940PW C5 G1	20,0	3,5	3,3	3,1	4,5	4,3	4,1
929001490680	Fortimo LEDFlex 2500lm/m 927 C5 G1	22,5	3,1	2,9	2,8	4,0	3,8	3,6
929001490780	Fortimo LEDFlex 2500lm/m 965 C5 G1	20,0	3,5	3,3	3,1	4,5	4,3	4,1

If you have a question on a specific combination, please contact your local sales representative.

Driver mapping

Tabel 3. Maximum meters LEDFlex per driver type with 90% driver load. If this value is bigger than the maximum allowed string length (see table 1 or 2); create a parallel connection.

		Description	LED Power Driver 20W 24V			LED Power Driver 80W - 24V		
		12NC	9290 006 54006			9290 016 69406		
		Type	build-in			build-in		
		Class 2 UL Certified	class 2			class 2		
		extension wire length (m)	0	5 (-5%)	10 (-10%)	0	5 (-5%)	10 (-10%)
12 NC	Discription	Power (W/m)						
929001490880	Fortimo LEDFlex 1000lm/m 830 C10 G1	7,1	2,5	2,4	2,3	10,1	9,6	9,1
929001490980	Fortimo LEDFlex 1000lm/m 840 C10 G1	6,6	2,7	2,6	2,5	10,9	10,4	9,8
929001491080	Fortimo LEDFlex 1000lm/m 827 C10 G1	7,4	2,4	2,3	2,2	9,7	9,2	8,8
929001491180	Fortimo LEDFlex 1000lm/m 865 C10 G1	6,6	2,7	2,6	2,5	10,9	10,4	9,8
929001491280	Fortimo LEDFlex 1500lm/m 830 C10 G1	10,9	1,7	1,6	1,5	6,6	6,3	5,9
929001491380	Fortimo LEDFlex 1500lm/m 840 C10 G1	10,0	1,8	1,7	1,6	7,2	6,8	6,5
929001491480	Fortimo LEDFlex 1500lm/m 827 C10 G1	11,2	1,6	1,5	1,4	6,4	6,1	5,8
929001491580	Fortimo LEDFlex 1500lm/m 865 C10 G1	10,0	1,8	1,7	1,6	7,2	6,8	6,5
929001491680	Fortimo LEDFlex 2000lm/m 830 C10 G1	14,9	1,2	1,1	1,1	4,8	4,6	4,3
929001491780	Fortimo LEDFlex 2000lm/m 840 C10 G1	13,8	1,3	1,2	1,2	5,2	5,0	4,7
929001491880	Fortimo LEDFlex 2000lm/m 827 C10 G1	15,6	1,2	1,1	1,0	4,6	4,4	4,2
929001491980	Fortimo LEDFlex 2000lm/m 865 C10 G1	13,8	1,3	1,2	1,2	5,2	5,0	4,7
929001492080	Fortimo LEDFlex 2500lm/m 830 C10 G1	18,9	1,0	0,9	0,9	3,8	3,6	3,4
929001492180	Fortimo LEDFlex 2500lm/m 840 C10 G1	17,6	1,0	1,0	0,9	4,1	3,9	3,7
929001492280	Fortimo LEDFlex 2500lm/m 827 C10 G1	19,9	0,9	0,9	0,8	3,6	3,4	3,3
929001492380	Fortimo LEDFlex 2500lm/m 865 C10 G1	17,6	1,0	1,0	0,9	4,1	3,9	3,7
929001489280	Fortimo LEDFlex 1000lm/m 930PW C5 G1	8,2	2,2	2,1	2,0	8,8	8,3	7,9
929001489380	Fortimo LEDFlex 1000lm/m 940PW C5 G1	7,6	2,4	2,3	2,1	9,5	9,0	8,5
929001489480	Fortimo LEDFlex 1000lm/m 927 C5 G1	8,6	2,1	2,0	1,9	8,4	8,0	7,5
929001489580	Fortimo LEDFlex 1000lm/m 965 C5 G1	7,6	2,4	2,3	2,1	9,5	9,0	8,5
929001489680	Fortimo LEDFlex 1500lm/m 930PW C5 G1	12,6	1,4	1,4	1,3	5,7	5,4	5,1
929001489780	Fortimo LEDFlex 1500lm/m 940PW C5 G1	11,8	1,5	1,4	1,4	6,1	5,8	5,5
929001489880	Fortimo LEDFlex 1500lm/m 927 C5 G1	13,2	1,4	1,3	1,2	5,5	5,2	4,9
929001489980	Fortimo LEDFlex 1500lm/m 965 C5 G1	11,8	1,5	1,4	1,4	6,1	5,8	5,5
929001490080	Fortimo LEDFlex 2000lm/m 930PW C5 G1	17,1	1,1	1,0	0,9	4,2	4,0	3,8
929001490180	Fortimo LEDFlex 2000lm/m 940PW C5 G1	16,0	1,1	1,1	1,0	4,5	4,3	4,1
929001490280	Fortimo LEDFlex 2000lm/m 927 C5 G1	18,0	1,0	1,0	0,9	4,0	3,8	3,6
929001490380	Fortimo LEDFlex 2000lm/m 965 C5 G1	16,0	1,1	1,1	1,0	4,5	4,3	4,1
929001490480	Fortimo LEDFlex 2500lm/m 930PW C5 G1	21,2	0,8	0,8	0,8	3,4	3,2	3,1
929001490580	Fortimo LEDFlex 2500lm/m 940PW C5 G1	20,0	0,9	0,9	0,8	3,6	3,4	3,2
929001490680	Fortimo LEDFlex 2500lm/m 927 C5 G1	22,5	0,8	0,8	0,7	3,2	3,0	2,9
929001490780	Fortimo LEDFlex 2500lm/m 965 C5 G1	20,0	0,9	0,9	0,8	3,6	3,4	3,2

If you have a question on a specific combination, please contact your local sales representative.

Driver mapping

Tabel 3. Maximum meters LEDFlex per driver type with 90% driver load. If this value is bigger than the maximum allowed string length (see table 1 or 2); create a parallel connection.

		Description	LED Power Driver 100W - 24V			LED Power Driver 150W 24VDC 120-240V		
			9290 016 69506			9290 014 85580		
		Type	build-in			build-in		
		Class 2 UL Certified	no			no		
		extension wire length (m)	0	5 (-5%)	10 (-10%)	0	5 (-5%)	10 (-10%)
12 NC	Discription	Power (W/m)						
929001490880	Fortimo LEDFlex 1000lm/m 830 C10 G1	7,1	12,7	12,0	11,4	19,0	18,1	17,1
929001490980	Fortimo LEDFlex 1000lm/m 840 C10 G1	6,6	13,6	13,0	12,3	20,5	19,4	18,4
929001491080	Fortimo LEDFlex 1000lm/m 827 C10 G1	7,4	12,2	11,6	10,9	18,2	17,3	16,4
929001491180	Fortimo LEDFlex 1000lm/m 865 C10 G1	6,6	13,6	13,0	12,3	20,5	19,4	18,4
929001491280	Fortimo LEDFlex 1500lm/m 830 C10 G1	10,9	8,3	7,8	7,4	12,4	11,8	11,1
929001491380	Fortimo LEDFlex 1500lm/m 840 C10 G1	10,0	9,0	8,6	8,1	13,5	12,8	12,2
929001491480	Fortimo LEDFlex 1500lm/m 827 C10 G1	11,2	8,0	7,6	7,2	12,1	11,5	10,8
929001491580	Fortimo LEDFlex 1500lm/m 865 C10 G1	10,0	9,0	8,6	8,1	13,5	12,8	12,2
929001491680	Fortimo LEDFlex 2000lm/m 830 C10 G1	14,9	6,0	5,7	5,4	9,1	8,6	8,2
929001491780	Fortimo LEDFlex 2000lm/m 840 C10 G1	13,8	6,5	6,2	5,9	9,8	9,3	8,8
929001491880	Fortimo LEDFlex 2000lm/m 827 C10 G1	15,6	5,8	5,5	5,2	8,7	8,2	7,8
929001491980	Fortimo LEDFlex 2000lm/m 865 C10 G1	13,8	6,5	6,2	5,9	9,8	9,3	8,8
929001492080	Fortimo LEDFlex 2500lm/m 830 C10 G1	18,9	4,8	4,5	4,3	7,1	6,8	6,4
929001492180	Fortimo LEDFlex 2500lm/m 840 C10 G1	17,6	5,1	4,9	4,6	7,7	7,3	6,9
929001492280	Fortimo LEDFlex 2500lm/m 827 C10 G1	19,9	4,5	4,3	4,1	6,8	6,4	6,1
929001492380	Fortimo LEDFlex 2500lm/m 865 C10 G1	17,6	5,1	4,9	4,6	7,7	7,3	6,9
929001489280	Fortimo LEDFlex 1000lm/m 930PW C5 G1	8,2	11,0	10,4	9,9	16,5	15,6	14,8
929001489380	Fortimo LEDFlex 1000lm/m 940PW C5 G1	7,6	11,8	11,3	10,7	17,8	16,9	16,0
929001489480	Fortimo LEDFlex 1000lm/m 927 C5 G1	8,6	10,5	9,9	9,4	15,7	14,9	14,1
929001489580	Fortimo LEDFlex 1000lm/m 965 C5 G1	7,6	11,8	11,3	10,7	17,8	16,9	16,0
929001489680	Fortimo LEDFlex 1500lm/m 930PW C5 G1	12,6	7,1	6,8	6,4	10,7	10,2	9,6
929001489780	Fortimo LEDFlex 1500lm/m 940PW C5 G1	11,8	7,6	7,2	6,9	11,4	10,9	10,3
929001489880	Fortimo LEDFlex 1500lm/m 927 C5 G1	13,2	6,8	6,5	6,1	10,2	9,7	9,2
929001489980	Fortimo LEDFlex 1500lm/m 965 C5 G1	11,8	7,6	7,2	6,9	11,4	10,9	10,3
929001490080	Fortimo LEDFlex 2000lm/m 930PW C5 G1	17,1	5,3	5,0	4,7	7,9	7,5	7,1
929001490180	Fortimo LEDFlex 2000lm/m 940PW C5 G1	16,0	5,6	5,3	5,1	8,4	8,0	7,6
929001490280	Fortimo LEDFlex 2000lm/m 927 C5 G1	18,0	5,0	4,8	4,5	7,5	7,1	6,8
929001490380	Fortimo LEDFlex 2000lm/m 965 C5 G1	16,0	5,6	5,3	5,1	8,4	8,0	7,6
929001490480	Fortimo LEDFlex 2500lm/m 930PW C5 G1	21,2	4,2	4,0	3,8	6,4	6,0	5,7
929001490580	Fortimo LEDFlex 2500lm/m 940PW C5 G1	20,0	4,5	4,3	4,1	6,8	6,4	6,1
929001490680	Fortimo LEDFlex 2500lm/m 927 C5 G1	22,5	4,0	3,8	3,6	6,0	5,7	5,4
929001490780	Fortimo LEDFlex 2500lm/m 965 C5 G1	20,0	4,5	4,3	4,1	6,8	6,4	6,1

If you have a question on a specific combination, please contact your local sales representative.

Driver mapping

Tabel 3. Maximum meters LEDFlex per driver type with 90% driver load. If this value is bigger than the maximum allowed string length (see table 1 or 2); create a parallel connection.

		Description	LED Power Driver 240W 24VDC 120-240V		
		12NC	9290 021 02080		
		Type	build-in		
		Class 2 UL Certified	no		
		extension wire length (m)	0	5 (-5%)	10 (-10%)
12 NC	Discription	Power (W/m)			
929001490880	Fortimo LEDFlex 1000lm/m 830 C10 G1	7,1	30,4	28,9	27,4
929001490980	Fortimo LEDFlex 1000lm/m 840 C10 G1	6,6	32,7	31,1	29,5
929001491080	Fortimo LEDFlex 1000lm/m 827 C10 G1	7,4	29,2	27,7	26,3
929001491180	Fortimo LEDFlex 1000lm/m 865 C10 G1	6,6	32,7	31,1	29,5
929001491280	Fortimo LEDFlex 1500lm/m 830 C10 G1	10,9	19,8	18,8	17,8
929001491380	Fortimo LEDFlex 1500lm/m 840 C10 G1	10,0	21,6	20,5	19,4
929001491480	Fortimo LEDFlex 1500lm/m 827 C10 G1	11,2	19,3	18,3	17,4
929001491580	Fortimo LEDFlex 1500lm/m 865 C10 G1	10,0	21,6	20,5	19,4
929001491680	Fortimo LEDFlex 2000lm/m 830 C10 G1	14,9	14,5	13,8	13,0
929001491780	Fortimo LEDFlex 2000lm/m 840 C10 G1	13,8	15,7	14,9	14,1
929001491880	Fortimo LEDFlex 2000lm/m 827 C10 G1	15,6	13,8	13,2	12,5
929001491980	Fortimo LEDFlex 2000lm/m 865 C10 G1	13,8	15,7	14,9	14,1
929001492080	Fortimo LEDFlex 2500lm/m 830 C10 G1	18,9	11,4	10,9	10,3
929001492180	Fortimo LEDFlex 2500lm/m 840 C10 G1	17,6	12,3	11,7	11,0
929001492280	Fortimo LEDFlex 2500lm/m 827 C10 G1	19,9	10,9	10,3	9,8
929001492380	Fortimo LEDFlex 2500lm/m 865 C10 G1	17,6	12,3	11,7	11,0
929001489280	Fortimo LEDFlex 1000lm/m 930PW C5 G1	8,2	26,3	25,0	23,7
929001489380	Fortimo LEDFlex 1000lm/m 940PW C5 G1	7,6	28,4	27,0	25,6
929001489480	Fortimo LEDFlex 1000lm/m 927 C5 G1	8,6	25,1	23,9	22,6
929001489580	Fortimo LEDFlex 1000lm/m 965 C5 G1	7,6	28,4	27,0	25,6
929001489680	Fortimo LEDFlex 1500lm/m 930PW C5 G1	12,6	17,1	16,3	15,4
929001489780	Fortimo LEDFlex 1500lm/m 940PW C5 G1	11,8	18,3	17,4	16,5
929001489880	Fortimo LEDFlex 1500lm/m 927 C5 G1	13,2	16,4	15,5	14,7
929001489980	Fortimo LEDFlex 1500lm/m 965 C5 G1	11,8	18,3	17,4	16,5
929001490080	Fortimo LEDFlex 2000lm/m 930PW C5 G1	17,1	12,6	12,0	11,4
929001490180	Fortimo LEDFlex 2000lm/m 940PW C5 G1	16,0	13,5	12,8	12,2
929001490280	Fortimo LEDFlex 2000lm/m 927 C5 G1	18,0	12,0	11,4	10,8
929001490380	Fortimo LEDFlex 2000lm/m 965 C5 G1	16,0	13,5	12,8	12,2
929001490480	Fortimo LEDFlex 2500lm/m 930PW C5 G1	21,2	10,2	9,7	9,2
929001490580	Fortimo LEDFlex 2500lm/m 940PW C5 G1	20,0	10,8	10,3	9,7
929001490680	Fortimo LEDFlex 2500lm/m 927 C5 G1	22,5	9,6	9,1	8,6
929001490780	Fortimo LEDFlex 2500lm/m 965 C5 G1	20,0	10,8	10,3	9,7

If you have a question on a specific combination, please contact your local sales representative.

Electromagnetic compatibility (EMC)

Electromagnetic compatibility (EMC) is the ability of a device or system to operate satisfactorily in its electromagnetic environment without causing unacceptable interference in practical situations. In general, LED modules have limited effect on the EMC of a luminaire. In some cases EMC needs to be improved.

How to... Improve EMC performance.

As mentioned before, the total amount of parasitic current needs to be minimized. For that reason, the following practical precautions need to be taken into account in a lighting system to minimize EMC:

- Minimize the DM loop area of the lamp wires going from the driver to the light source by keeping the wires close together (bundling). This will minimize the magnetic field and reduce the radiated EMC. Long linear light sources are also part of that loop.
- Keep mains and control wires (DALI, 0-10 V) separated from the output wires (do not bundle).
- Sometimes, radiated EMC compliance cannot be achieved, necessitating the use of a 100 ... 300 Ω axial

ferrite bead(s) for either mains or lamp wiring (effective for interference between 30 MHz and 300 MHz), or coupling the wires through ferrite cores within the luminaire may improve the overall EMC performance. However, selection of the type and characteristics of the additional filter depends on what frequency components have to be damped and by how much. Adhering to these rules will help in EMC compliance. For further questions, please contact your local Philips representative. Alternatively, the Philips Lighting OEM Design-In team could be consulted for a possible solution.

Chemical compatibility

In the current market medium power LEDs exist, containing a silver-finished (Ag) Lead frame. The lead frame finish is sensitive to pollution and or corrosion when exposed to Oxygen and certain Volatile Organic Components [VOCs]. Examples of VOCs are substances containing Sulfur or Chlorine. In that case parts of the lead frame may blacken, which will impair the lumen output or the color point of the LED light. Materials that are known to have a higher risk to be a source of Sulfur and Chlorine are for example natural rubbers used for cables, cable entries or sealing, or corrugated carton. Also be careful using adhesives, cleaning agents, coatings and applications in aggressive (corrosive) environments. We recommend ensuring that the direct environment of these LEDs in the luminaire does not contain materials that can be a source of Sulfur or Chlorine, for optimal reliability of the LED, LED module and/or LED luminaire. Furthermore, make sure that the products with these LEDs are not stored or used in vicinity of sources of Sulfur or Chlorine, and the production environment is also free of these materials. Also avoid cleaning of the LED products with these

types of LEDs with abrasive substances, brushes or organic solvents like Acetone and TCE. Applications of the product in industry and heavy traffic environment should be avoided in case of risk of ingress of Sulfur and Chlorine from the environment. The Philips LEDFlex family makes use of LEDs with above explained type of lead frame. Therefore above recommendations apply for the Philips LEDFlex. A list of chemicals, often found in electronics and construction materials for luminaires that should be avoided, is provided in the table on the left. Note that Philips does not warrant that this list is exhaustive since it is impossible to determine all chemicals that may affect LED performance. These chemicals may not be directly used in the final products but some of them may be used in intermediate manufacturing steps (e.g. cleaning agents). Consequently, trace amounts of these chemicals may remain on (sub) components, such as heat sinks. It is recommended to take precautions when designing your application. In case of questions on compatibility of materials or applications of the product please contact your Philips representative for application support.

Chemical name	Normally used as
Acetic	Acid
Hydrochloric acid	Acid
Nitric acid	Acid
Sulfuric acid	Acid
Ammonia	Alkali
Potassium hydroxide	Alkali
Sodium hydroxide	Alkali
Acetone	Solvent
Benzene	Solvent
Dichloromethane	Solvent
Gasoline	Solvent
MEX (Methyl Ethly Ketone)	Solvent
MKB (Methyl Isobutyl Ketone)	Solvent
Mineral spirits (turpentine)	Solvent
Tetracholorometane	Solvent
Toluene	Solvent
Xylene	Solvent
Castor oil	Oil
Lard	Oil
Linseed	Oil
Petroleum	Oil
Silicone oil	Oil
Halogenated hydrocarbons (containing F, Cl, BR elements)	Misc
Rosin flux	Solder flux
Acrylic tape	Adhesive
Cyanoacrylate	Adhesive

Examples of system calculation

Example 1:

I need a 3-meter line of light of Fortimo LEDFlex 1500lm/m 930PW C5 G1 for an application in Italy with an independent driver and 5 meter extension cable.

1. Determine the wattage of the LEDFlex. See datasheet or table 3 in the DIG for power consumption → $12.6\text{W/m} \rightarrow 3 \times 12.6 = 50.4$ Watt
2. Determine the driver. See table 3 and pick matching independent driver → LED Transformer 60W 24VDC
3. Determine how many meters can be placed on one driver, table 3 → 4.3 meter
4. Check the Tc in the luminaire, Tc=65 degree C
5. Check in table 1 the maximum LEDFlex length at Tc 65 with 5 meter extension cable → 7.5meter → $4.3 < 7.5 \rightarrow \text{ok}$
6. Conclusion: 3 meter of this LEDFlex can be connected in one string to the 60Watt transformer.

Example 2:

I need a 45-meter line of light of Fortimo LEDFlex 1000lm/m 940PW C5 G1 for a cove lighting application in Germany with a built-in driver and 10 meter extension cable.

1. Determine the wattage of the LEDFlex. See datasheet or table 3 in the DIG → $7.6\text{W/m} \rightarrow 45 \times 7.6 = 320$ Watt
2. Determine the driver. See table 3 and pick matching build-in driver → 2x LED Power Driver 240W 24VDC 120-240V
3. Determine how many meters can be placed on one driver, table 3 → 28.4 meter
4. Check the Tc in the luminaire. In this case: Tc=65 degree C.
Check in table 1 the maximum LEDFlex length at Tc 65 with 10 meter extension cable → max. 9 meter LEDFlex allowed to avoid dimming due to voltage drop → parallel strings needed → 3 strings of 7.5 meter per driver
5. Extension cable type to use; check datasheet of the 240W driver → 2.0mm² (AWG14)
6. Conclusion: 45 meter of this LEDFlex can be connected using two pieces of 240Watt driver. Each driver powering 3 strings of LEDFlex of 7.5 meter. Extension wire to be used 2.0mm² (AWG14) max length 10 meters



© 2019 Signify Holding. All rights reserved. The information provided herein is subject to change, without notice. Signify does not give any representation or warranty as to the accuracy or completeness of the information included herein and shall not be liable for any action in reliance thereon. The information presented in this document is not intended as any commercial offer and does not form part of any quotation or contract, unless otherwise agreed by Signify.

Philips and the Philips Shield Emblem are registered trademarks of Koninklijke Philips N.V. All other trademarks are owned by Signify Holding or their respective owners.

06/2019
Data subject to change

www.philips.com/oem
www.philips.com/ledmodulesna
NA Customer Support/Technical Service: Tel. (1)800-372-3331